



PRODUCT FEATURES

- Low-Cost IEEE 802.3af PD Module
- High Efficiency
- Low EMI
- IEEE 802.3af (13W), POE PD Modules
- On board PI filter for output ripple control
- Overload and short circuit protection¹
- Highly efficient 1500V isolated DC-DC converter
- Adjustable output voltage
- RoHS compliant
- World's smallest full power 802.3af (POE) solution
- Ultra Compact Size (35mm x 14mm)
- 3.3V, 5V, 12V DC output voltage models
- IEEE 802.3af, Type 1 802.3at and 802.3bt
- Wide input voltage (36V to 57V DC)
- Full Power start up even from 36V input
- Minimal external components required
- Low output ripple and noise

PRODUCT OVERVIEW

The PEM1400 is the world's smallest full power IEEE802.3af compliant Power Over Ethernet (PoE)Powered Device (PD) module delivering up to 12.95W of power across all its voltage variants, 3.3V(PEM1403), 5V (PEM1405), and 12V (PEM1412). Its low-cost design requires just input diodes and an output capacitor to rapidly enable a POE solution.

The ultra-compact size of 35mm x 14mm (1.38in x 0.55in) occupies just 390 mm² (0.605 sq. inches) of footprint on the customer's board making ideal for compact new generation devices like IOT, IP phones, IP cameras, security and access control devices, sensors, routers, and network access points. The PEM1400 has an isolated high efficiency DC-DC converter with in-built frequency dithering to reduce EMI and noise

With on board PI filter, the output ripple is controlled within IEEE specifications.

APPLICATION AREAS

- Security and alarm systems
- Voice over IP phones
- Access control systems
- IP Cameras
- Displays, Net Monitors
- Public address systems
- Wireless access points
- Environmental control
- Telemetry
- Remote environmental monitoring

¹ If maximum power is exceeded, the PEM1400 will operate in over current mode and will auto recover when the over load condition is removed.

Table of Contents

PRODUCT SELECTOR	3
INPUT CHARACTERISTICS	3
DC OUTPUT CHARACTERISTICS.....	3
ABSOLUTE MAXIMUM RATINGS	3
TYPICAL INPUT CONNECTIONS	4
OUTPUT CONNECTION	4
BLOCK DIAGRAM	4
PIN CONNECTIONS	5
INPUTS.....	5
TYPICAL SYSTEM CONFIGURATION	5
POWERED DEVICE (PD) SIGNATURE	6
ISOLATION	6
FREQUENCY DITHERING	6
OUTPUT VOLTAGE ADJUSTMENT	6
THERMAL MANAGEMENT	7
POWER PLANE HEAT SINK	8
EFFICIENCY V/S OUTPUT LOAD	9
LOAD REGULATION V/S OUTPUT LOAD.....	10
LINE REGULATION	11
PHYSICAL PACKAGE.....	12
APPLICATION NOTES.....	12
ESD AND SURGE PROTECTION.....	12
ROHS, REACH AND CONFLICT MINERALS COMPLIANCE	12
REVISION HISTORY	13

Table of Figures

Figure 1- Typical Input Connections	4
Figure 2- Output Connection.....	4
Figure 3- Block Diagram	4
Figure 4- Typical System configuration.....	5
Figure 5- PEM1403 Output Voltage Adjustment.....	6
Figure 6- PEM1405 Output Voltage Adjustment.....	7
Figure 7- PEM1412 Output Voltage Adjustment.....	7
Figure 8- Thermal Performance profile at nominal V_{in}	8
Figure 9- Power Plane Heat Sink	8
Figure 10- PEM1403 Efficiency vs. Output Load end to end.....	9
Figure 11- PEM1405 Efficiency vs. Output Load end to end.....	9
Figure 12- PEM1412 Efficiency vs. Output Load end to end.....	9
Figure 13- PEM1403 Load Regulation vs. Output Load end to end	10
Figure14- PEM1405 Load Regulation vs. Output Load end to end	10
Figure 15- PEM1412 Load Regulation vs. Output Load end to end	10
Figure 16- PEM1403 Line Regulation end to end	11
Figure 17- PEM1405 Line Regulation end to end	11
Figure 18- PEM1412 Line Regulation end to end	11
Figure 19- Mechanical Dimensions.....	12

PRODUCT SELECTOR

Part Number	Marking	Nominal Input Voltage (V_{IN})	Output Voltage ²	Efficiency ³	Power (Maximum) ^{7,10}
		(Volts DC)	(Volts DC)	(%)	(Watts)
PEM1403	03	48	3.3	80	12.95
PEM1405	05	48	5	85	12.95
PEM1412	12	48	12	87	12.95

INPUT CHARACTERISTICS

Parameter	Symbol	Min.	Typ ⁴ .	Max.	Units
Input Voltage ⁴	V_{IN}	36	48	57	Volts
Under Voltage Lockout	V_{UVLO}	30		36	Volts
Input Current ⁵	I_{IN}		350	400	mA
Operating Temperature ⁶	T_{OP}	-20	25	70	°C
IEEE 802.3af Power Classification ⁷	Class 0				

DC OUTPUT CHARACTERISTICS

Parameter	Symbol	Min.	Typ ⁴ .	Max.	Units
Line Regulation ⁸	V_{LNRG}		0.2%		
Load Regulation ⁸	PEM1405 and PEM1412		0.5%		
	PEM1403		0.8%		
Output Ripple and Noise ⁸	V_{RIP}		80		mV p-p
Isolation Voltage	V_{ISOL}			1500	V DC
Temperature Coefficient (Slope)	TC		100	300	ppm/°C

ABSOLUTE MAXIMUM RATINGS^{8,9}

Supply Voltage (V_{CC})	0V – 57V DC
Storage Temperature (T_S)	-25°C – 100°C
Output Voltage (V_{OUT})	0V to controlled output voltage (operating or non-operating)

² Output voltage typical $\pm 3\%$ at T_A of 25°C with a nominal input voltage, rated output current and typical connections.

³ At nominal V_{IN} at full load.

⁴ With minimum load 1Watt or 100mA, whichever is higher.

⁵ Please refer to IEEE802.3af standards document.

⁶ Please see Thermal Management Section.

⁷ Please see Powered Device Signature Section.

⁸ All specifications typical are at T_A of 25°C with a nominal input voltage and rated output current unless otherwise noted. These are meant as a design aid only and are indicative, and not guaranteed.

⁹ Exceeding the absolute maximum ratings may cause permanent damage to the product. We do not imply functional operation under these conditions. These ratings assume free air flow.

TYPICAL INPUT CONNECTIONS

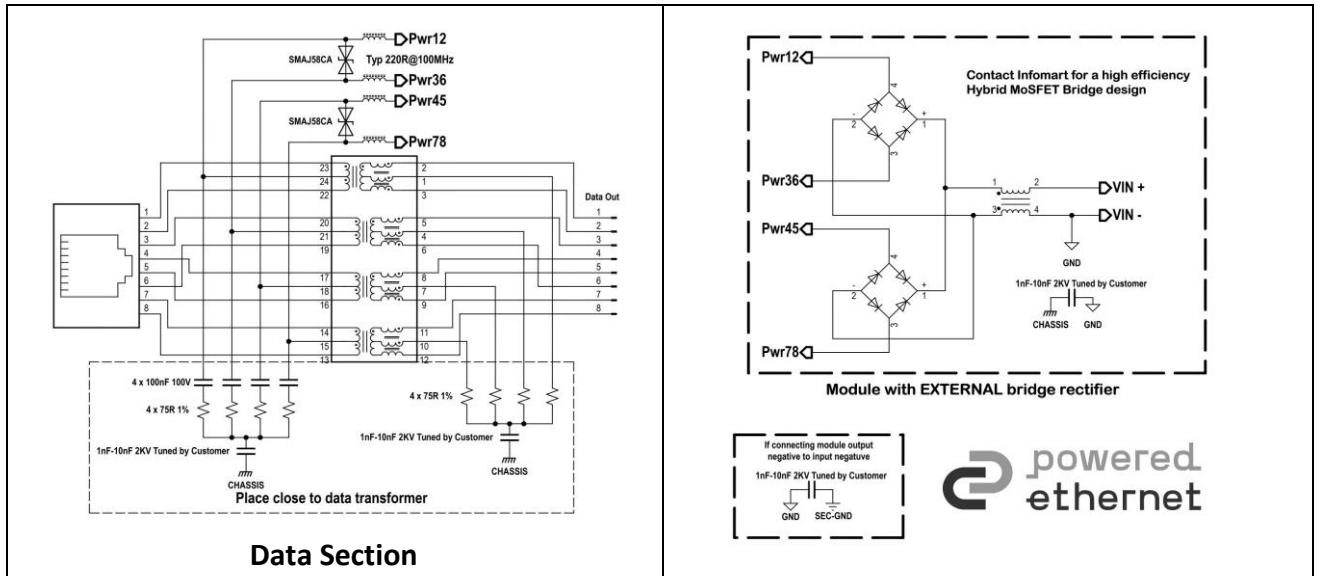

Figure 1- Typical Input Connections

OUTPUT CONNECTION

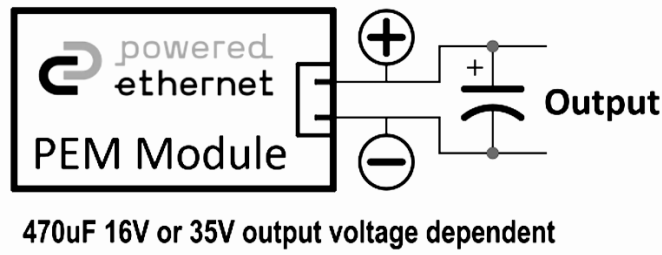

Figure 2- Output Connection

BLOCK DIAGRAM

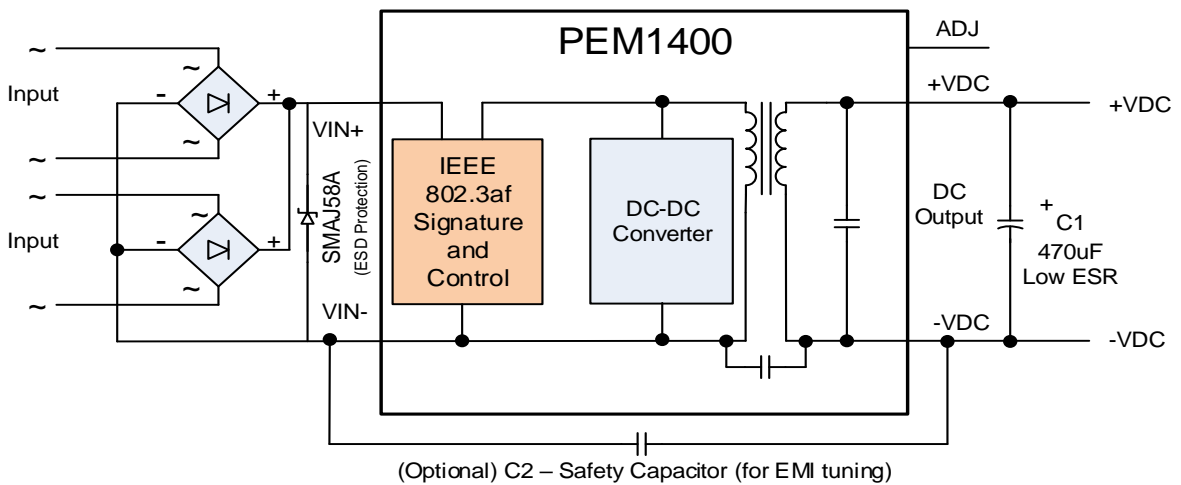

Figure 3- Block Diagram

PIN CONNECTIONS

INPUT PINS	
1	VIN+ . This pin connects to the positive (+) output of the input bridge rectifiers.
2	VIN- . This pin connects to the negative (-) output of the input bridge rectifiers.
OUTPUT PINS	
3	+VDC . This pin provides the regulated output from the DC/DC converter. Max. Current 3A per pin ¹⁰ .
4	OADJ . The output voltage can be adjusted from its nominal value, by connecting an external resistor from this pin to either +VDC pin or -VDC pin. For more details, see <i>OUTPUT VOLTAGE ADJUSTMENT</i> Section.
5	-VDC . The ground return for +VDC output. Max. Current 3A per pin ¹⁰ .
To maintain isolation integrity, always connect respective input and output poles only via X or Y safety capacitor. Maintain isolation barrier on motherboard PCB as per physical package.	

INPUTS

The PEM1400 is compatible with all IEEE 802.3af compliant Power Sourcing Equipment (PSE) and supports the different power injection options of Data/Signal pair (Mode A) or Spare Pair (Mode B). See *Figure 4*. As per IEEE 802.3af, it is specified that the PSE does not apply power to the both outputs at the same time i.e. 4 pair injection. (Refer to IEEE802.3af standards for more information).

The PEM1400 provides for external input bridge rectifiers for improved system design flexibility, and distribution of heat generation. As an example, a system designer wanting to provide two RJ45 inputs, both of which are PoE enabled, but use only one PEM1400 module to save costs. Another advantage is that this allows the system designer to control the type and costs of the input rectification diodes.

TYPICAL SYSTEM CONFIGURATION

In Mode A – Signal Pair injection, the signal lines carry both data and power. In Mode B – Spare Pair injection, the Signal pair carries only data, and the spare pair carries power.

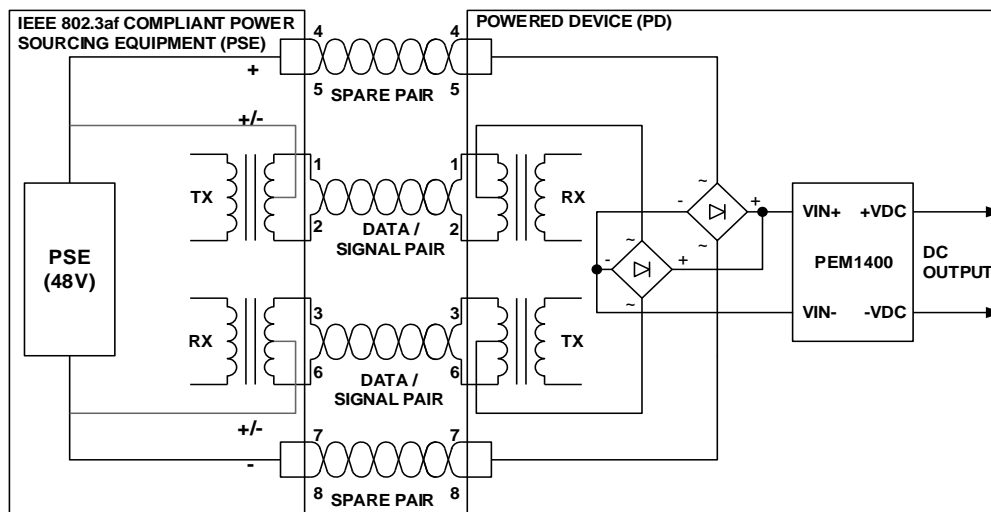

Figure 4- Typical System configuration

¹⁰ Max. Current 4A per pin for PEM1403

POWERED DEVICE (PD) SIGNATURE

When the PEM1400 is connected to a Cat 5e or greater Ethernet cable from an IEEE 802.3af compliant Power Sourcing Equipment (PSE), Endspan or Midspan, it will automatically present a Powered Device (PD) signature to the PSE, as and when requested. The PSE will then recognise that a PD is connected to that line and supply power.

The PEM1400 presents class 0 detection to the PSE.

ISOLATION

IEEE802.3af section 33.4.1 calls for a Powered Device (PD) to meet safety isolation requirement by meeting the electrical strength test of IEC 60950 sub clause 6.2. Infomart's® PoweredEthernet™ PEM1400 modules meet or exceed 1500V impulse test. This is also referred to as 'Hi Pot Test', 'Flash Tested', 'Withstand Voltage', 'Proof Voltage', 'Dielectric Withstand Voltage' & 'Isolation Test Voltage'.

FREQUENCY DITHERING

The PEM1400 series is built with Frequency Dithering to help better controlling of EMI (electromagnetic-interference) emissions. The nominal switching frequency of PEM1400 series is 300KHz, with a dithering range of +/- 10%.

OUTPUT VOLTAGE ADJUSTMENT

The PEM1400 series has an OADJ pin, which allows the output voltage to be increased or decreased from its nominal value using a 1/16W power rating or greater and 1% tolerance resistor connected between the OADJ pin and either the +VDC or -VDC pin as per Shown below. Only one connection i.e. between OADJ and +VDC **or** between OADJ and -VDC is permitted at a time. A change of more than ± 10% from nominal is not permitted. Please [contact Infomart technical support](#) for more details or specific resistor values.

An estimate of resistance value for voltage adjustment is provided below. The most appropriate resistance value to be tuned by customers.

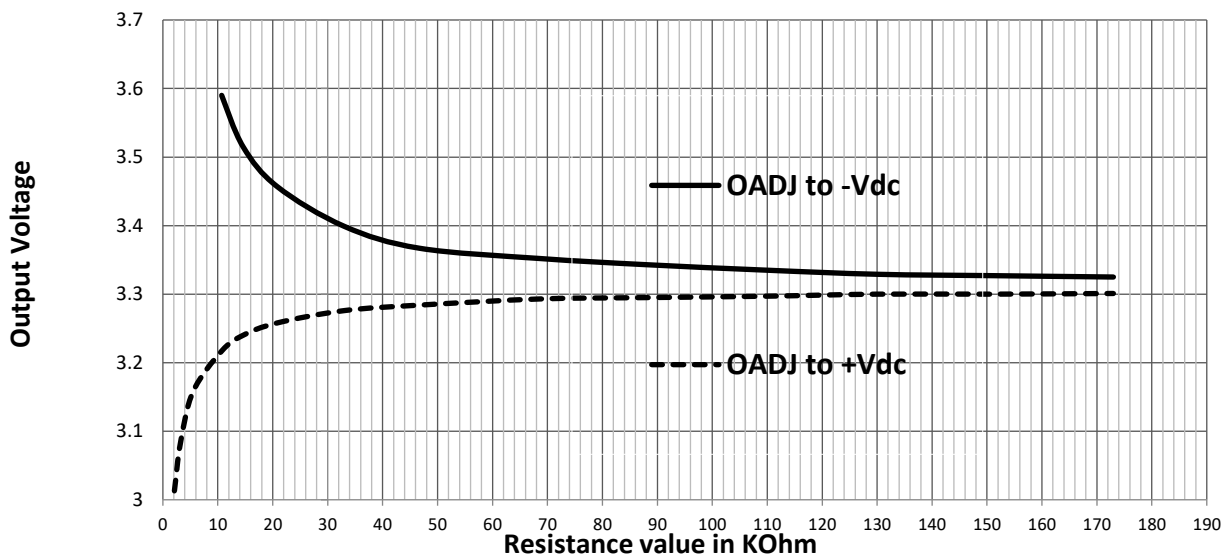

Figure 5- PEM1403 Output Voltage Adjustment

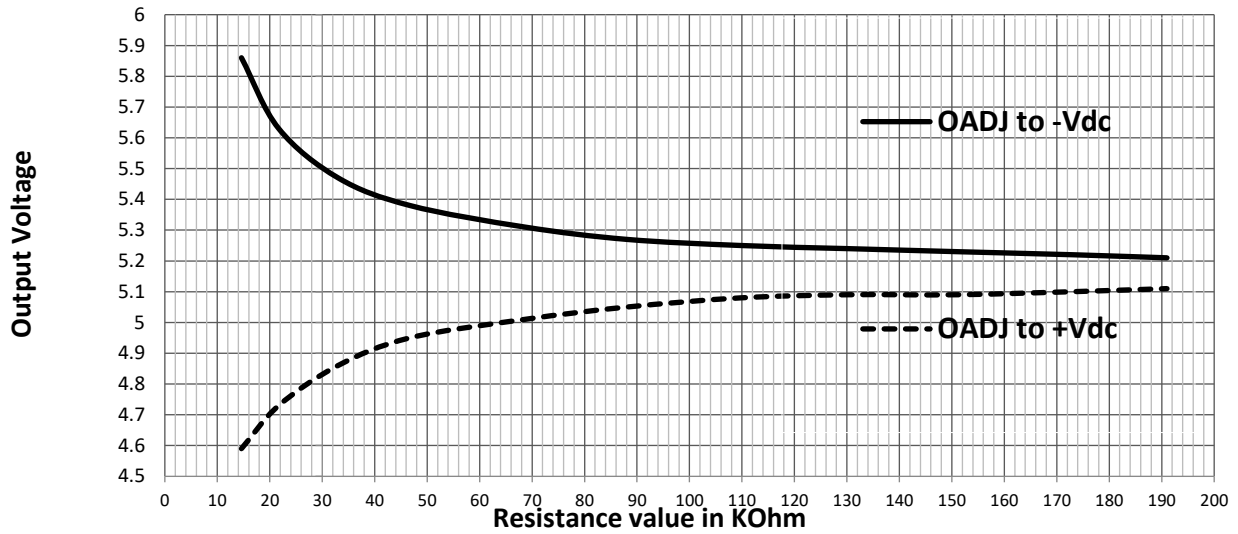

Figure 6- PEM1405 Output Voltage Adjustment

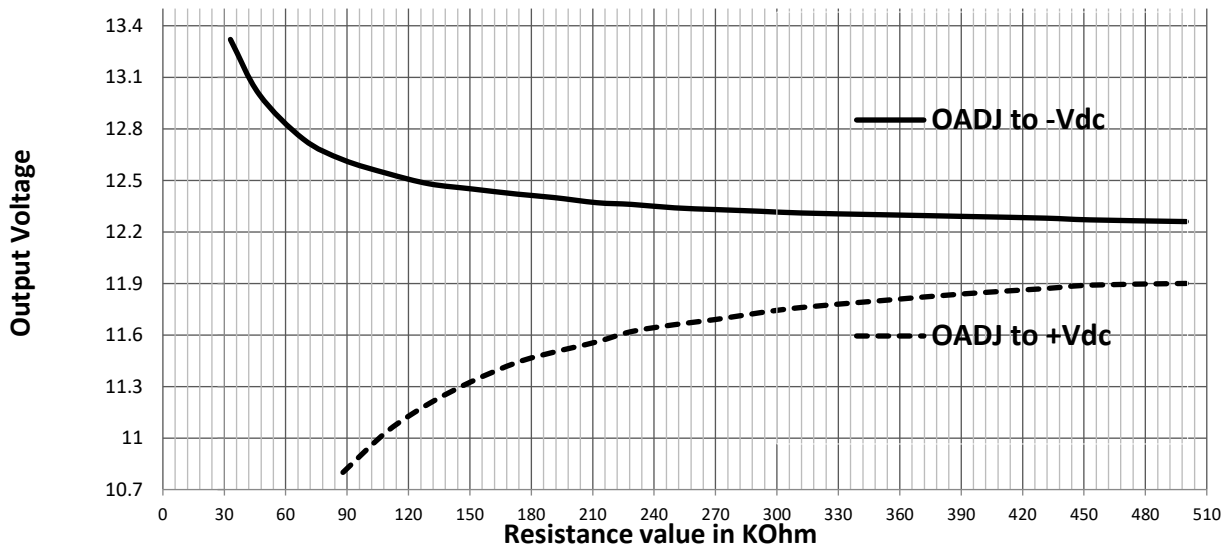

Figure 7- PEM1412 Output Voltage Adjustment

THERMAL MANAGEMENT

As with any power component, the PEM1400 modules generate heat. It is important that adequate ventilation and airflow be taken into consideration at the design stage. The quantum of heat generated by the PEM1400 will depend on the output load it is required to drive. The maximum ambient operating temperature is 70°C. Figure below shows the thermal performance of the PEM1400 with a nominal 48VDC input. The PEM1400 thermal performance can be improved by forced airflow cooling over the module and by using a heat sink (a) glued on to the output diodes using a thermal glue, or (b) by a power plane heat sink as described below. The two methods can be combined.

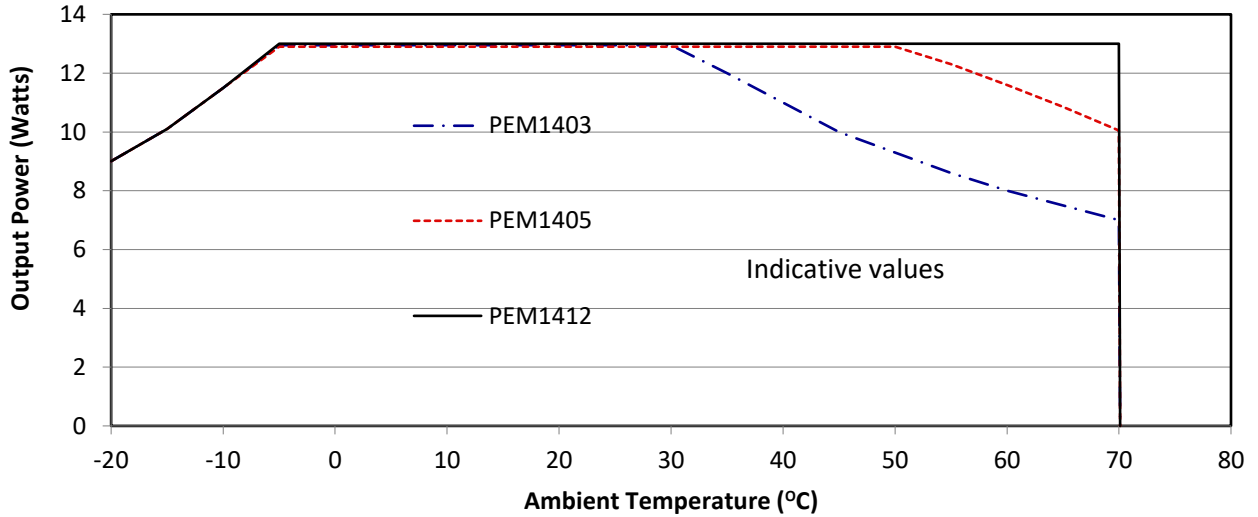

Figure 8- Thermal Performance profile at nominal V_{in}

POWER PLANE HEAT SINK

A power plane heat sink on the motherboard is a relatively simple method to draw some heat away from the PEM1400 using the output pins (+VDC and -VDC) which are connected to a PCB heat sink on the motherboard. **It is important to maintain electrical isolation between OADJ pin and the +VDC and -VDC pins to ensure proper output voltages.**

These power plane heat sinks must be on the outer layers of the PCB and the PEM1400 must not be fitted into a socket. This method can be combined with forced airflow cooling, and with a heat sink glued on to the two output diodes using a thermal glue.

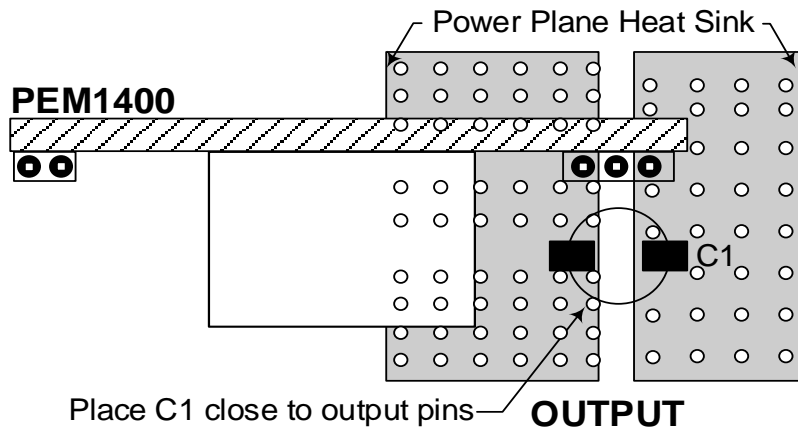

Figure 9- Power Plane Heat Sink

EFFICIENCY v/s OUTPUT LOAD

(indicative values from one of our data)

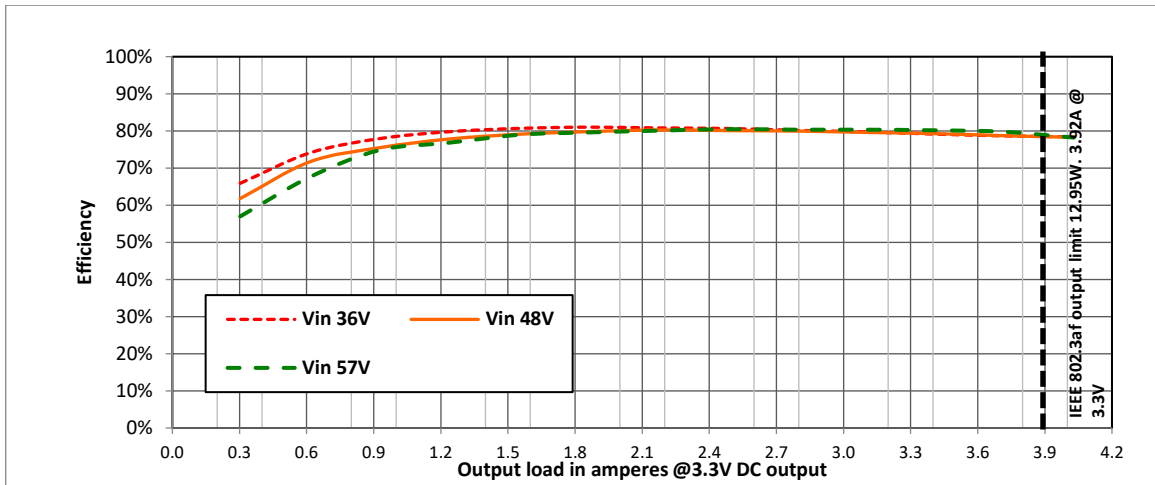

Figure 10- PEM1403 Efficiency vs. Output Load end to end

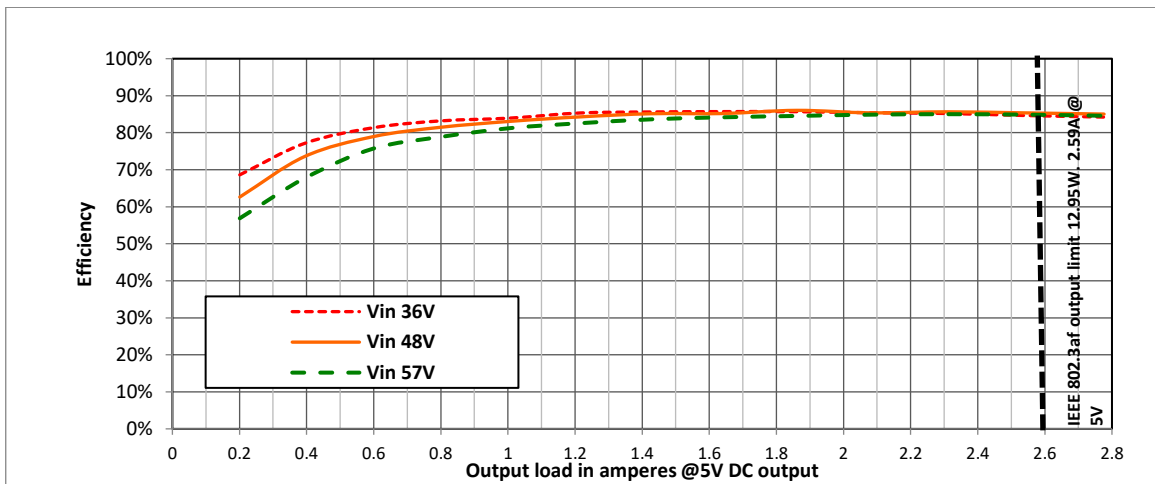

Figure 11- PEM1405 Efficiency vs. Output Load end to end

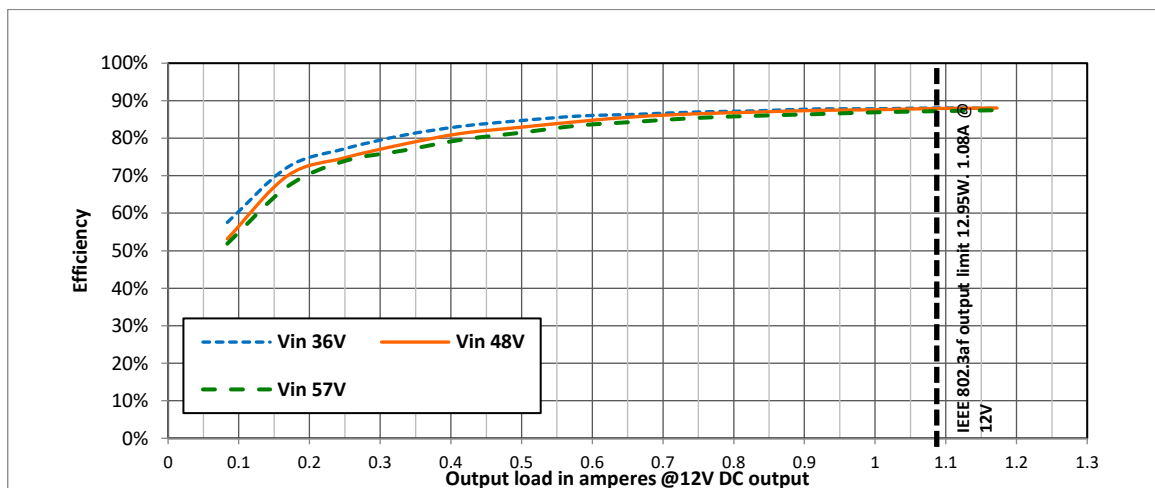

Figure 12- PEM1412 Efficiency vs. Output Load end to end

LOAD REGULATION v/s OUTPUT LOAD

(indicative values from one of our data)

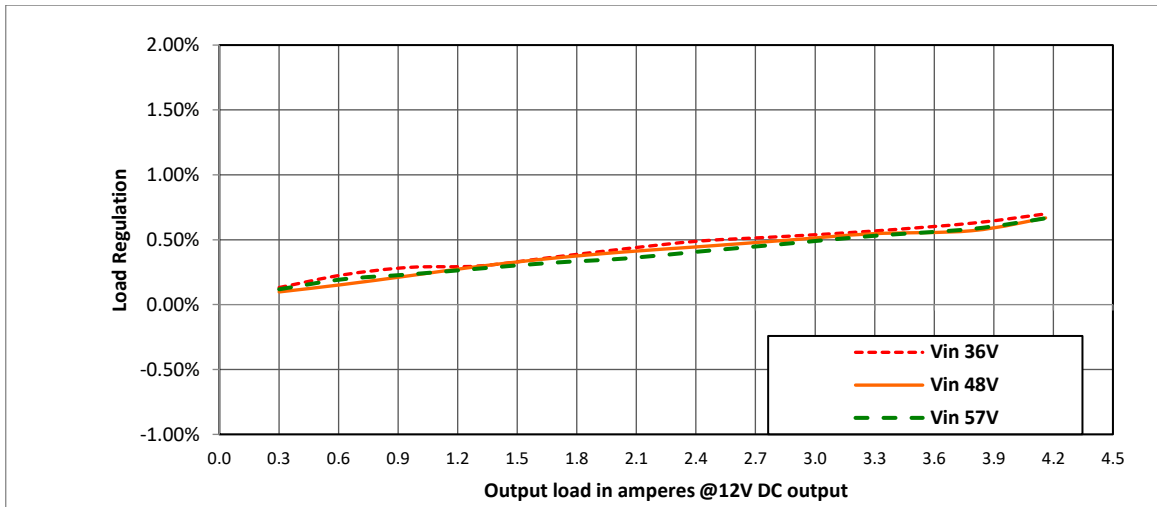

Figure 13- PEM1403 Load Regulation vs. Output Load end to end

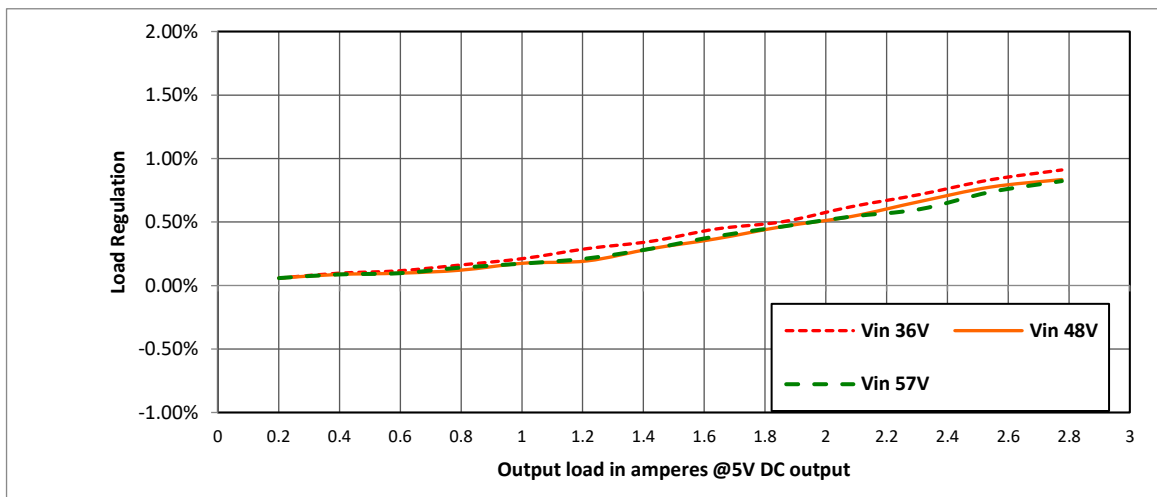

Figure14- PEM1405 Load Regulation vs. Output Load end to end

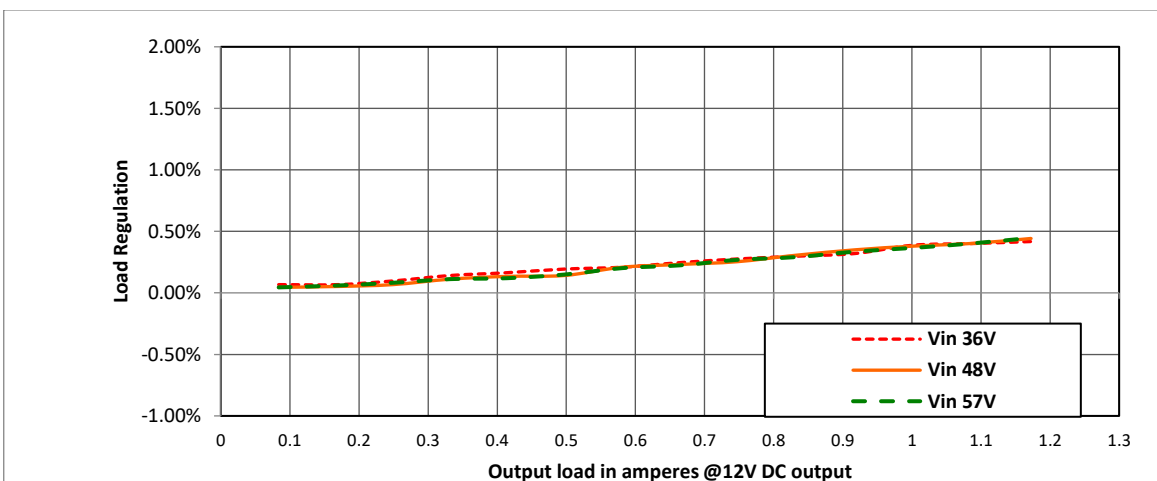

Figure 15- PEM1412 Load Regulation vs. Output Load end to end

LINE REGULATION

(indicative values from one of our data)

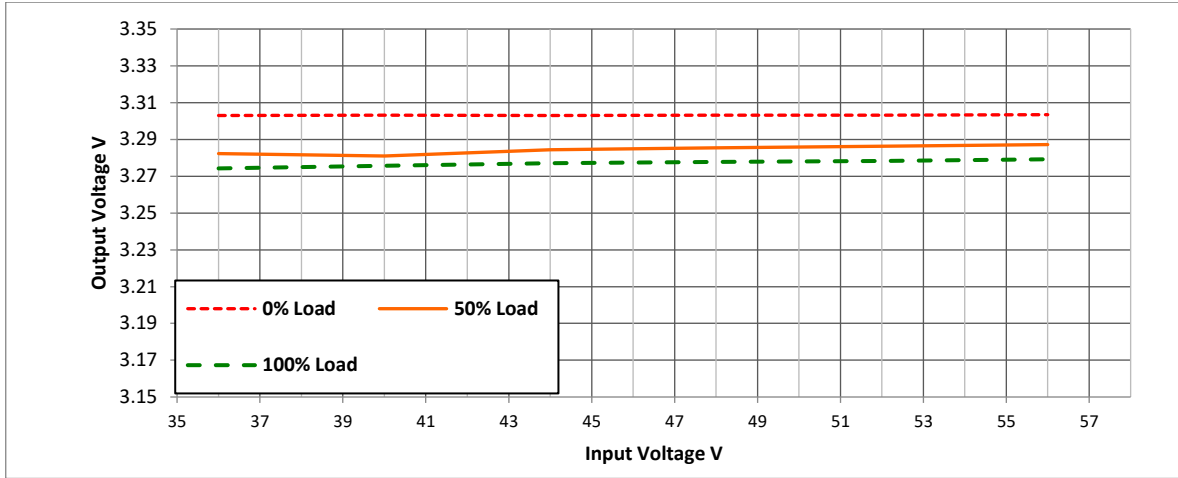

Figure 16- PEM1403 Line Regulation end to end

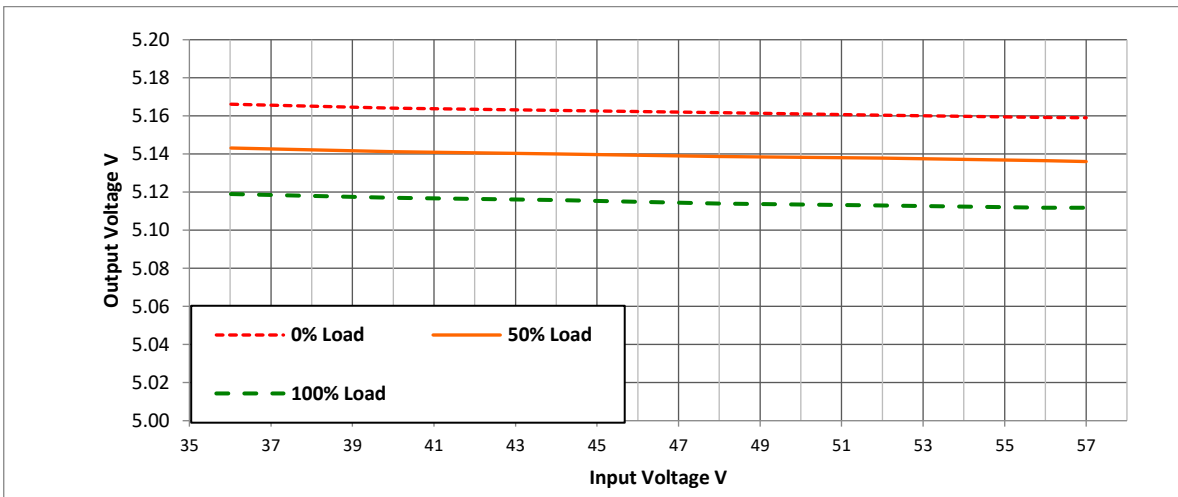

Figure 17- PEM1405 Line Regulation end to end

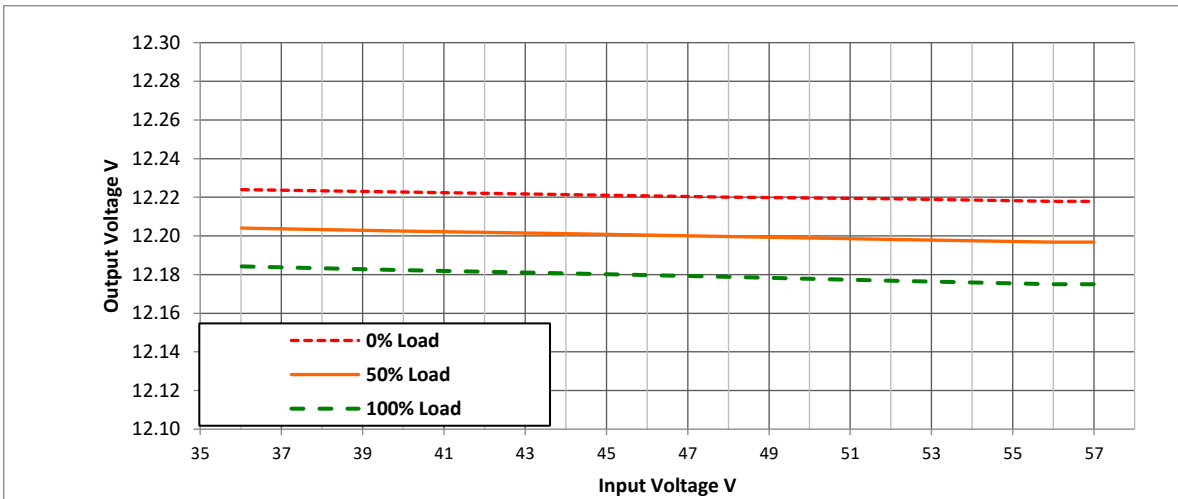

Figure 18- PEM1412 Line Regulation end to end

PHYSICAL PACKAGE

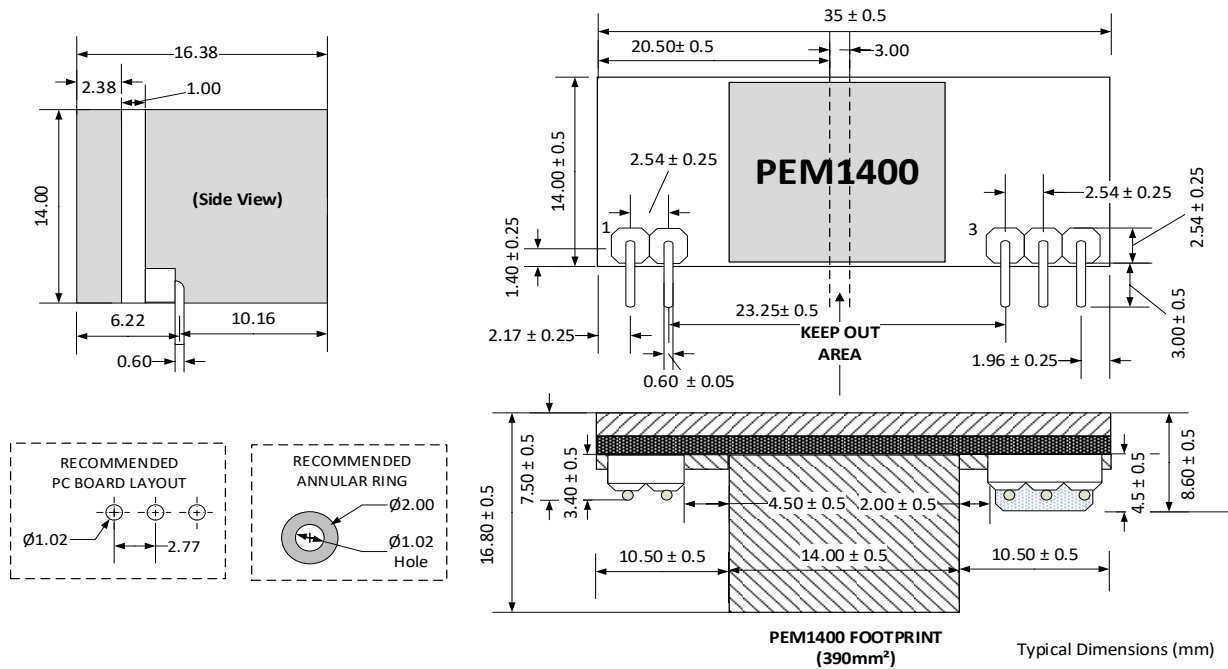

Figure 19- Mechanical Dimensions

APPLICATION NOTES

Power Over Ethernet (PoE) is a technology for wired Ethernet, the most widely installed local area network technology in use today. PoE allows the electrical power necessary for the operation of each end-device to be carried by data cables along with the data, rather than by separate power cords. Thus, it minimizes the number of wires used to install the network, resulting in lower cost, less downtime, easier maintenance and greater installation flexibility.

The IEEE standard governing PoE is IEEE802.3af. Compliance with this standard ensures inter-operability between devices.

The PEM1400 series modules offering a modular solution, incorporating full IEEE802.3af compatibility signature to the PSE and isolated on-board DC/DC converter. The PEM1400 series are ideal modular system blocks allowing manufacturers of Ethernet equipment to “PoE enable” their equipment with minimal effort and cost. The PEM1400 modules series offer simple and quicker product development, maximising return on investment.

PEM1400 can be powered using a user designed power supply which has adequate thermal and over-current protection. It is strongly recommended that only IEEE802.3af compliant power supply equipment be used to prevent damage to the module, which lacks output stage thermal protection.

ESD AND SURGE PROTECTION

It is required that the system designer must provide ESD and surge protection such as a TVS diode, like SMAJ58A (Uni-Directional) or SMAJ58CA (bi-directional), at the PEM1400 input to prevent damage from over-voltage surges and for system EMC / ESD compliance.

ROHS, REACH and CONFLICT MINERALS COMPLIANCE

ROHS, REACH, and Conflict Minerals compliance details are available on our website.

REVISION HISTORY

REVISION NUMBER	DESCRIPTION
21GR1-1	<ul style="list-style-type: none"> ▪ Image of the Product changed ▪ PRODUCT OVERVIEW and PRODUCT FEATURES updated ▪ Clerical and aesthetic changes ▪ Mechanical dimensions updated ▪ Revision History added to Data sheet template
24JR1	<ul style="list-style-type: none"> ▪ Updated OUTPUT CONNECTION diagram
24LR1	<ul style="list-style-type: none"> ▪ Updated IEEE802.3 POWER LEVELS AND CLASSES
25AR4	<ul style="list-style-type: none"> ▪ Updated Dimension of keep out area
25CR5	<ul style="list-style-type: none"> ▪ Update in PHYSICAL PACKAGE

IEEE802.3 POWER LEVELS AND CLASSES

IEEE 802.3 Power levels and Classifications for POE Powered Devices

IEEE Standard	Common Name	PD Class	PD / PSE Type	Max num. of events	PD Power ¹	PSE Power ²	Wire pairs energised	AUC ³
802.3af	POE	0	1	-	12.95W	15.4W	2	No Support
802.3af	POE	1	1	1	3.84W	4W	2	No Support
802.3af	POE	2	1	1	6.49W	7W	2	No Support
802.3af	POE	3	1	1	12.95W	15.4W	2	No Support
802.3at	POE+	4	2	2	25.5W	30W	2	No Support
802.3bt	POE++	5	3	4	38.25W	45W	4	Optional
802.3bt	POE++	6	3	4	51W	60W	4	Optional
802.3bt	POE+++	7	4	5	62W	75W	4	Optional
802.3bt	POE+++	8	4	5	71.3W	90W	4	Optional

¹ Min. power delivered to PD / Module input. Max. PD / module output depends on operating conditions

² Power delivered from the Power Sourcing Equipment (PSE) (switch or injector) at its output port

³ Auto Class is supported. It is optional to enable or not.

www.poweredethernet.com. E.&O.E.

**Infomart India Pvt. Ltd.**

Infomart Tech Park

99, 5th Cross, 5th Block, Koramangala

Bangalore – 560 095, India

Tel: +91 80 4111-7200

Email: pesales@infomartgroup.com**Infomart Technologies**

Americas sales office

5904, South Cooper St. #104-96

Arlington, Texas, 76017, USA

Tel: +1 903-270-9090

Infomart India Pvt. Ltd. (Infomart®) products are sold subject to the general terms and conditions of commercial sale, as published at www.poweredethernet.com unless otherwise agreed on a written agreement. Infomart® reserves the right to make changes to any products herein, without further notice. The customer is responsible for its products and applications using Infomart® products, including compliance with all laws, regulations and safety requirements or standards, regardless of any support or applications information provided by Infomart®. “Typical” parameters which may be provided in Infomart® data sheets and / or in specifications can and do vary in different applications and actual performance may vary over time. Infomart® makes no warranty, representation or guarantee regarding the suitability of its products for any particular purpose, nor does Infomart® assume any liability arising out of the application or use of any product or circuit, and specifically disclaims any and all liability, including without limitation special, consequential or incidental damages. All operating parameters, including “Typical” must be validated for each customer application by customer’s technical experts. Infomart® products are not designed, intended, or authorized for use as a critical component in life support systems or any FDA Class 3 medical devices or medical devices with a same or similar classification in a foreign jurisdiction or any devices intended for implantation in the human body. Should Buyer purchase or use Infomart® products for any such unintended or unauthorized application, Buyer shall indemnify and hold Infomart® or and its officers, employees, subsidiaries, affiliates, and distributors harmless against all claims, costs, damages, and expenses, and reasonable attorney fees arising out of, directly or indirectly, any claim of personal injury or death associated with such unintended or unauthorised use, even if such claim alleges that Infomart® was negligent regarding the design or manufacture of the part. This document is subject to all applicable copyright laws and is not for resale and may not be altered in any manner. Infomart is a registered trademark of Infomart® (India) Pvt. Ltd. PoweredEthernet™ is a trademark of Infomart (India) Pvt. Ltd.

