

PRODUCT FEATURES

- Low-Cost, small size IEEE 802.3at PD Module, Class 4
- Low EMI
- Adjustable operating frequency¹
- 30W peak and 24W continuous output power²
- Low output ripple and noise
- Adjustable output voltage
- Continuous output short circuit and overload protection³
- RoHS compliant
- Dedicated pin for Auxiliary Power, Remote Shut down
- High efficiency
- 12V, 19V and 24V DC output voltage models
- Highly efficient 1500V isolated DC-DC converter
- “AT Detect” pin for layer 2 classification
- Compact package and minimum PCB footprint
- Minimal external component required (470uF x 1 ECAP on output side)

PRODUCT OVERVIEW

The PEM3200 is globally one of the smallest size, full power IEEE802.3at and IEEE802.3af compliant Power Over Ethernet (PoE) Powered Device (PD) extraction module delivering up to 30 watts peak power, when sourced from a competent power IEEE 802.3at Power Sourcing Equipment (PSE), using twisted pair CAT5 or higher Ethernet cable. It offers fixed POE Class 4 and Two Event Physical Layer (Layer 1) classification, as per IEEE802.3at and supports layer 2 classification via an “AT Detect” pin. The module also supports Type 1 and Type 2 PD operation of the IEEE 802.3bt.

The PEM3200 output ripple is controlled within IEEE specifications. For improved EMI performance and featured with in-built frequency dithering and a dedicated pin for adjusting the switching frequency for additional tuning for targeted EMI filtration. It supports external Auxiliary DC power and enables Remote Shut Down to keep POE supply on standby mode.

The PEM3200 is a low-cost solution with a high efficiency DC-DC converter with 1500V safety isolation, in-built under-voltage, over-voltage, output over-load and short-circuit protection. It requires minimal external components and provide a quick, easy, and cost-effective method for Ethernet equipment manufacturers to “PoE enable” their equipment.

It is ideal for POE applications for IP & PTZ cameras, gaming instruments, audio & video interfaces, security and access control devices, door monitoring, sensors, environment control devices, routers, and network access points.

APPLICATION AREAS

- Security and alarm systems
- Voice over IP phones
- Access control systems
- IP Cameras
- Displays, Net Monitors
- Public address systems
- Wireless access points
- Environmental control
- Telemetry
- Remote environmental monitoring

¹ Please see *FREQUENCY ADJUSTMENT* section.

² 30Watt peak for maximum 30sec. at duty cycle of 10%. Please see *THERMAL MANAGEMENT* section for operating temperature.

³ If maximum power is exceeded, Module will operate in an over current mode and auto recover when the overload condition is removed.

Table of Contents

PRODUCT SELECTOR	3
INPUT CHARACTERISTICS	3
DC OUTPUT CHARACTERISTICS	3
ABSOLUTE MAXIMUM RATINGS	3
TYPICAL INPUT CONNECTIONS	4
OUTPUT CONNECTION	4
BLOCK DIAGRAM	4
PIN CONNECTIONS.....	5
INPUTS	5
POWERED DEVICE (PD) SIGNATURE AND POWER CLASS PROGRAMMING.....	5
ISOLATION.....	6
IEEE POE POWER CLASSIFICATION METHOD	6
AT DETECTION (ATD PIN)	6
REMOTE SHUTDOWN (RSD)	7
OUTPUT VOLTAGE ADJUSTMENT.....	8
FREQUENCY DITHERING	8
FREQUENCY ADJUSTMENT	8
THERMAL MANAGEMENT	8
POWER PLANE HEAT SINK	9
PHYSICAL PACKAGE	10
APPLICATION NOTES.....	10
ESD AND SURGE PROTECTION	10
ROHS REACH AND CONFLICT MINERALS COMPLIANCE	10
REVISION HISTORY.....	11

Table of Figures

Figure 1- Typical Input Connections	4
Figure 2- Output Connection	4
Figure 3- Block Diagram	4
Figure 4- Two Event Physical Layer (Layer 1) classification.....	5
Figure 5- AT Detect Pin Connection	6
Figure 6- Remote Shut down Connection	7
Figure 7- Thermal Performance profile at nominal V_{in}	9
Figure 8- Power Plane Heat Sink	9
Figure 9- Mechanical Dimensions	10

PRODUCT SELECTOR⁴

Part Number	Marking	Output Voltage ⁵	Efficiency ⁶	IEEE Power Classification	Output Power (Maximum)
		(Volts DC)	(%)	(%)	(Watts)
PEM3212	12	12	89	Class 4	24 Watts continuous / 30 Watts peak
PEM3219	19	19	89	Class 4	24 Watts continuous / 30 Watts peak
PEM3224	24	24	89	Class 4	24 Watts continuous / 30 Watts peak

INPUT CHARACTERISTICS

Parameter	Symbol	Min.	Typ ⁶ .	Max.	Units
Input Voltage (DC) ⁷	V _{IN}	36	51	57	V
Under Voltage Lockout (DC)	V _{UVLO}	30		36	V
Input Current (DC) ⁸	I _{IN}	100 ^{8,9}		600	mA
Operating Temperature	T _{OP}	-20	25	70	°C
IEEE 802.3at/af Power Classification ¹⁰		Class 4			

DC OUTPUT CHARACTERISTICS

Parameter	Symbol	Min	Typ ⁶ .	Max.	Units
Line Regulation ⁹	V _{LNRG}		0.2%		
Load Regulation ⁹	V _{LDRG}		0.5%		
Output Ripple and Noise ^{4,9,11}	V _{RIP}		50	150	mV
Isolation Voltage (DC)	V _{ISOL}			1500	V
Temperature Coefficient (Slope)	TC		100	300	ppm/°C
Output Short Circuit Duration (at ambient 25°C)				∞	Sec

ABSOLUTE MAXIMUM RATINGS¹²

Supply Voltage (V _{CC})	0V – 57V DC
Storage Temperature (T _S)	-25°C – 100°C
Output Voltage (V _{OUT})	0V to controlled output voltage (operating or non-operating)

⁴ Electrical specifications and measurements in this data sheet are considered to be at the respective input and output pins, wherever applicable. All readings in this data sheet are considered to be at 25°C ambient, unless otherwise specified.

⁵ Output voltage typical ±3% at T_A for 25°C with a nominal input voltage and rated output current.

⁶ Typical at nominal V_{IN} at 67% load at T_A 25°C.

⁷ Ensure minimum output load of 1 Watt or 100mA input current whichever is higher.

⁸ Please refer to IEEE802.3at/af standards document.

⁹ Minimum current required to maintain power signature as per IEEE802.3af / at standards.

¹⁰ Please see *IEEE POE POWER CLASSIFICATION METHOD* section, for more details.

¹¹ Output Ripple measured along with and across the Out Put ECAP (Typical Connections)

¹² Exceeding the absolute maximum ratings may cause permanent damage to the product. We do not imply functional operation under these conditions. These ratings assume free air flow.

TYPICAL INPUT CONNECTIONS

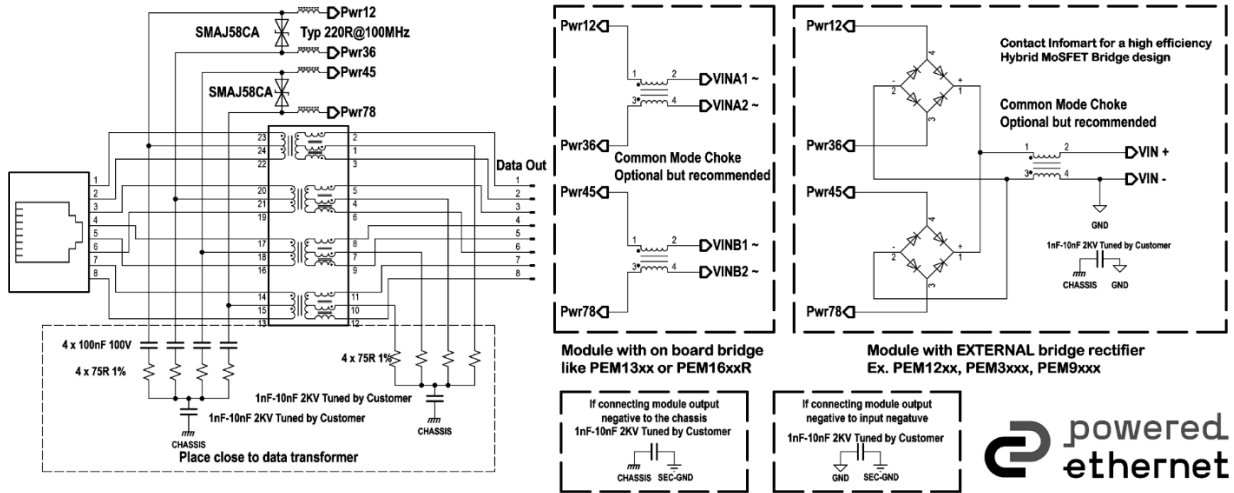
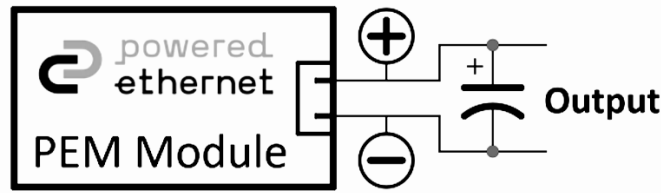

Figure 1- Typical Input Connections

OUTPUT CONNECTION



470uF 16V or 35V output voltage dependent

Figure 2- Output Connection

BLOCK DIAGRAM

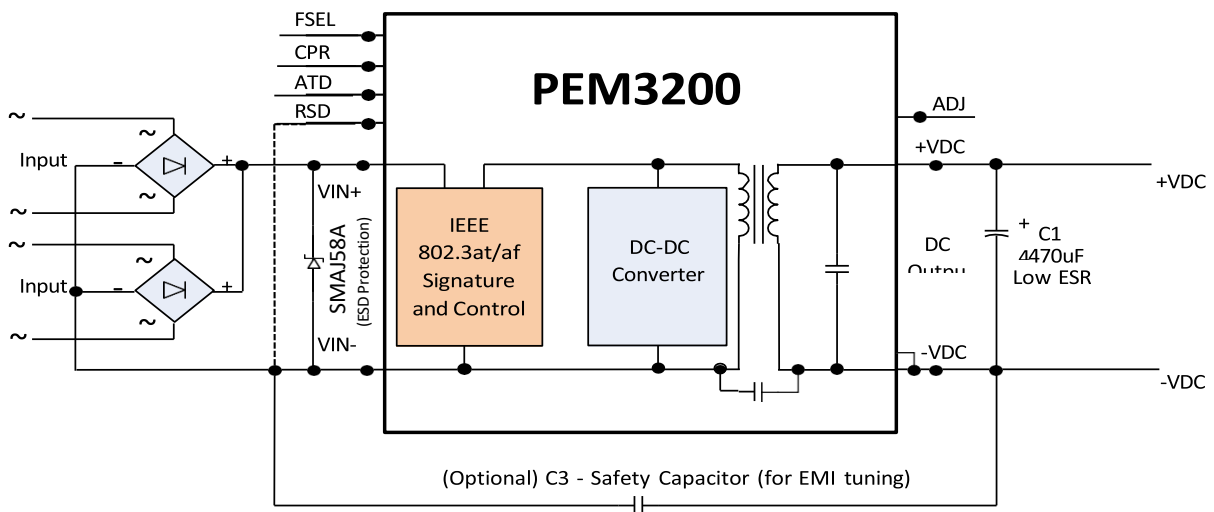

Figure 3- Block Diagram

PIN CONNECTIONS

INPUT PINS	
1	VIN+ . This pin connects to the positive (+) output of the input bridge rectifiers.
2	VIN- . This pin connects to the negative (-) output of the input bridge rectifiers.
3	ATD . AT Detect Pin. For more details see, <i>AT DETECTION (ATD Pin)</i>
4	RSD . This pin can be used for remotely shutting down the module from the target device. For more details see, <i>REMOTE SHUTDOWN (RSD)</i> . Section.
5	CPR . This pin is used for Remote Shut down. For more details see, <i>REMOTE SHUTDOWN (RSD)</i> . Section.
6	FSEL . This pin can be used for adjusting the switching frequency. For more details see, <i>FREQUENCY ADJUSTMENT</i> . Section.
OUTPUT PINS	
7	-VDC . The ground return for the +VDC output. (Internally connected to pin 10).
8	+VDC . This pin provides the regulated output from the DC/DC converter.
9	OADJ . The output voltage can be adjusted from its nominal value. For more details see, <i>OUTPUT VOLTAGE ADJUSTMENT</i> . Section.
10	-VDC . The ground return for the +VDC output. (Internally connected to pin 7).
To maintain isolation integrity, always connect respective input and output poles only via X or Y safety capacitor. Maintain isolation barrier on motherboard PCB as per physical package.	

INPUTS

The PEM3200 series is compatible with all IEEE 802.3af / at compliant Power Sourcing Equipment (PSE) and supports the different power injection options of Data/Signal pair (Mode A) or Spare Pair (Mode B). (Refer to IEEE802.3at and IEEE802.3af standards for more information).

PEM3200 provides for external input bridge rectifiers for improved system design flexibility, and distribution of heat generation. As an example, a system designer wants to provide two RJ45 inputs, both of which are PoE enabled, but wants to use only one PEM3200 module to save costs. Another advantage is that this allows the system designer to control the type and costs of the input rectification diodes.

POWERED DEVICE (PD) SIGNATURE and POWER CLASS PROGRAMMING

When PEM3200 is connected to a Cat 5e or greater Ethernet cable from an IEEE 802.3af/at compliant Power Sourcing Equipment (PSE), Endspan or Midspan, it will automatically present a Powered Device (PD) signature to the PSE, as and when requested. The PSE will then recognise that a PD is connected to that line and supply power.

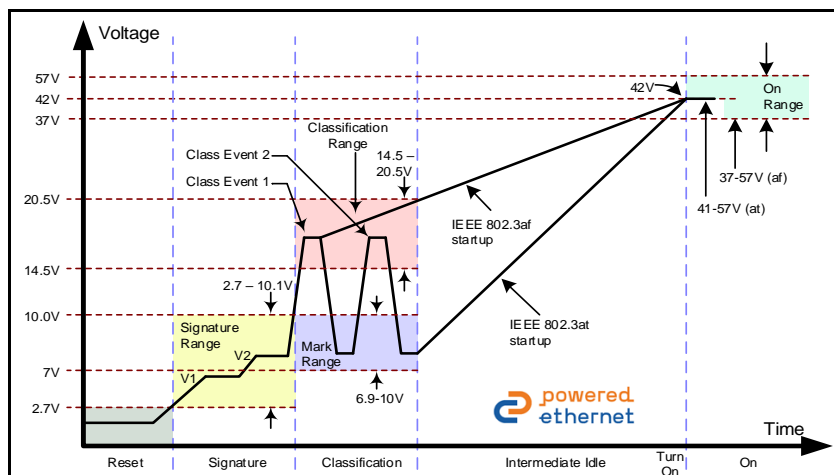

Figure 4- Two Event Physical Layer (Layer 1) classification

ISOLATION

IEEE 802.3af / at section 33.4.1 calls for a Powered Device (PD) to meet safety isolation requirement by meeting the electrical strength test of IEC 60950 sub clause 6.2. Infomart's® Powered Ethernet™ PEM3200 modules meet or exceed 1500V impulse test. This is also referred to as 'Hi Pot Test', 'Flash Tested', 'Withstand Voltage', 'Proof Voltage', 'Dielectric Withstand Voltage' & 'Isolation Test Voltage'.

IEEE POE POWER CLASSIFICATION METHOD

The PEM3200 classification is fixed to present the POE PD Class 4. If it connected to a Type 1 (IEEE802.3af) PSE, the PSE will default to Class 0. If it is connected to a Type 2 (IEEE802.3at) PSE, the PSE will recognise the PEM3200 as a Class 4 POE PD.

The PEM3200 supports Two Event Physical Layer (Layer 1) classification, as per IEEE802.3at, as shown in *Figure 4*, above. For Data Link Layer (Layer 2) (Data Link layer) see, *AT DETECTION (ATD Pin)* section below

AT DETECTION (ATD Pin)

If the PEM3200 detects a Type 2 PSE via the Two Event Physical Layer method, it asserts the ATD pin high (+5V), indicating connection to a Type 2 PSE. If the PD controller detects only a single event classification, it identifies the PSE to be Type 1 and the ATD pin is asserted Low.

As per the IEEE 802.3at standards, to extract more than 15.4W power from the PSE the host board controller has to inform the PSE through the Layer 2 (data link layer) that it is a Type-2 POE PD. Full details are available in the IEEE 802.3at standards document.

The PEM3200 ATD pin can be connected to the host board through an optocoupler as shown in *Figure 5* below.

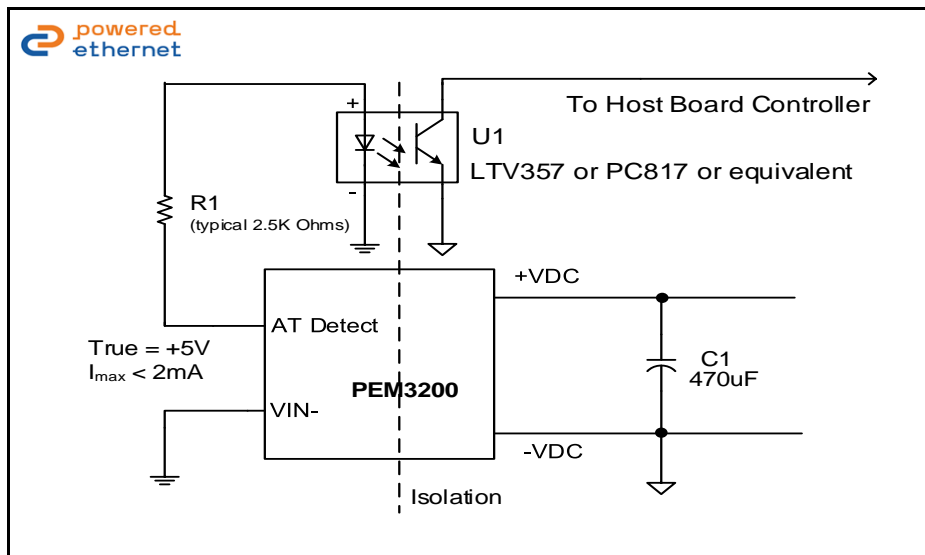

Figure 5- AT Detect Pin Connection

The value of R1 resistor should be selected to ensure the **maximum current remains below 2mA at all times**. The collector pin of U1 should be connected to the host board controller, via a pull-up resistor. When connected to a Type 2 PSE the +5V on the ATD pin turns on the opto-coupler U1, and its output goes low (Logical Zero). Using this, the host board controller can sense that the PSE can deliver more than 15.4W and confirm to the PSE via Data Link Layer it is a Type 2 PD.

If the PEM3200 does not detect a Two Event Physical Layer classification, the ATD pin will remain low, thus U1 remains OFF and its output collector remains high via the pull-up resistor.

In case the Physical Layer classification is not supported by the PSE, then U1 remains OFF.

REMOTE SHUTDOWN (RSD)

The PEM3200 series is featured with Remote Shut Down option, which can be used in case the host board need to shut down PEM3200. This feature is helpful with host boards having auxiliary power supply.

Using the remote shut down feature the designer can decide the priority of POE power or auxiliary power. For example, when the auxiliary power supply is live, the host board can shut down the PEM3200 output. Similarly, the RSD feature can be used to initiate a hardware reset by the host board based on SNMP.

The RSD pin can be connected to host board through an optocoupler as shown in *Figure 6* below. The optocoupler is required in order to maintain the 1500V isolation barrier.

To shut down the PEM3200 the host board needs to pull the RSD pin from Zero to High. When the RSD pin is activated, the output of the PEM3200 will switch off. RSD is a current-mode pin, the ratings are as per *Table 1*.

If the remote shutdown feature is not used, connect RSD to Vin-.

Description	Unit	Min	Type	Max
RSD pin threshold low	μA			20
RSD pin threshold high	μA	100		
Input voltage RSD pin	V			6

Table 1- Remote Shut Down

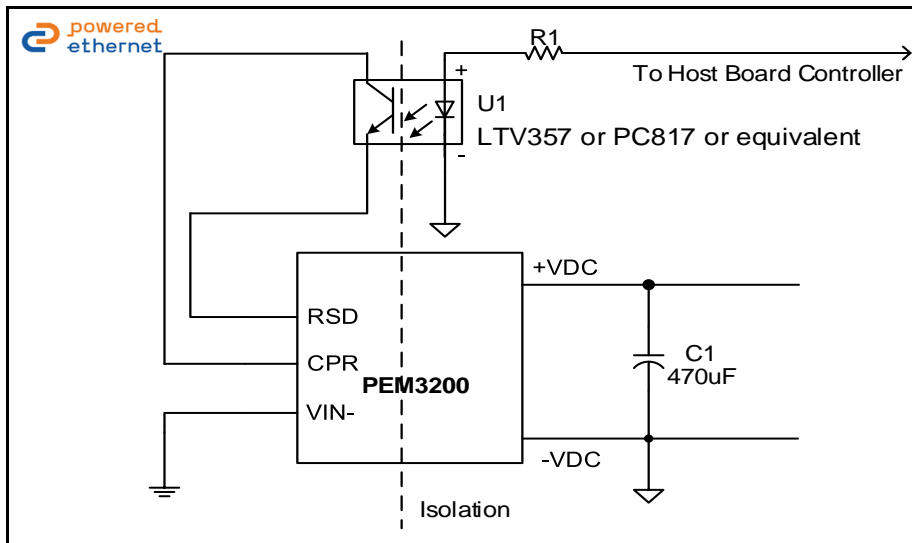

Figure 6- Remote Shut down Connection

If RSD is asserted, the ATDET pin is forced high, irrespective of the PD mode. See **Table 2** below for ATDET output definitions under various powering modes. Please contact Infomart technical support for more details.

ATDET signal status	PSE	
	Type 1	Type 2
RSD = Low	Low	High
RSD = High	High	High

Table 2- ATDET Truth Table

OUTPUT VOLTAGE ADJUSTMENT

The PEM 3200 series has an OADJ pin, which allows the output voltage to be increased or decreased from its nominal value using a 1/16W power rating or greater and 1% tolerance resistor. The resistor is to be connected between the OADJ pin and either the +VDC or –VDC pin as per the below table. Only one connection i.e. between OADJ and +VDC or between OADJ and –VDC is permitted at a time. Do not adjust output voltage by more than $\pm 10\%$ or $\pm 1.5V$, whichever is lower, from nominal voltage. Maximum output voltage on PEM3224 is 24.5V. The voltages are to be measured at the output pins of the module. Please [contact Infomart technical support](#) for any further clarifications. An estimate of resistance value for voltage adjustment is provided below. The most appropriate resistance value to be tuned by customers.

PEM3212			PEM3219		
Output Voltage	OADJ to +VDC	Output Voltage	OADJ to +VDC	Output Voltage	OADJ to +VDC
11V	117K Ω	11V	117K Ω	11V	117K Ω
11.5V	232K Ω	11.5V	232K Ω	11.5V	232K Ω
12V	DNP	12V	DNP	12V	DNP
12.50V		12.50V		12.50V	
13V		13V		13V	
PEM3224					
Output Voltage	OADJ to +VDC	Output Voltage	OADJ to +VDC	Output Voltage	OADJ to +VDC
22V	305K Ω	22V	305K Ω	22V	305K Ω
22.99V	606K Ω	22.99V	606K Ω	22.99V	606K Ω
24V	DNP	24V	DNP	24V	DNP
24.99V		24.99V		24.99V	
25.99V		25.99V		25.99V	

Table 3- Output Voltage Adjustment

FREQUENCY DITHERING

The PEM3200 series is built with Switching Frequency Dithering to help better controlling of EMI emissions and harmonics. The nominal switching frequency of PEM3200 is 300KHz, with a frequency dithering range of $\pm 10\%$.

FREQUENCY ADJUSTMENT

To provide greater flexibility in EMI control, the PEM3200 allows designers to increase the switching frequency, via the FSEL pin. This feature must be used with great care and in consultation with Infomart technical support. Always use a resistor of maximum 1% tolerance and minimum 1/16W power rating which should be connected between the FSEL pin and VIN- pin. As an example, about 900Kohm’s resistance will produce a 10% increase in frequency.

THERMAL MANAGEMENT

As with any power component, the PEM3200 modules generate heat. It is important that adequate ventilation and airflow be taken into consideration at the design stage. The quantum of heat generated by the PEM3200 will depend on the output load it is required to drive. The maximum ambient operating temperature is 70°C. Thermal performance of the PEM3200 series with a nominal 51VDC input is shown in *Figure 7* below.

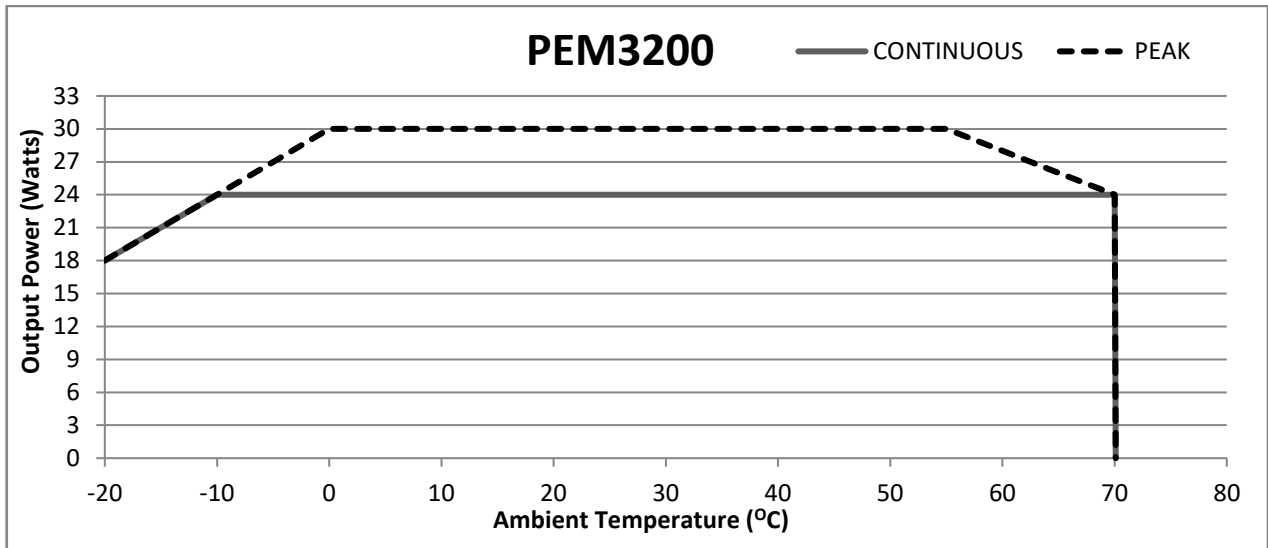

Figure 7- Thermal Performance profile at nominal V_{in}

POWER PLANE HEAT SINK

The PEM3200 thermal performance can be improved by forced airflow cooling over the module and by using (a) a heat sink glued on to the diodes using thermal glue or (b) a power plane heat sink described in *Figure 8* below. The two methods can be combined.

A power plane heat sink on the motherboard is a relatively simple method to draw some heat away from the PEM3200 using the output pins (-VDC and +VDC) which are connected to a PCB heat sink on the motherboard. **It is important to maintain electrical isolation mutually between the OADJ pin, the EMO pin, the +VDC pin, and the -VDC pin in order to ensure proper output voltages.**

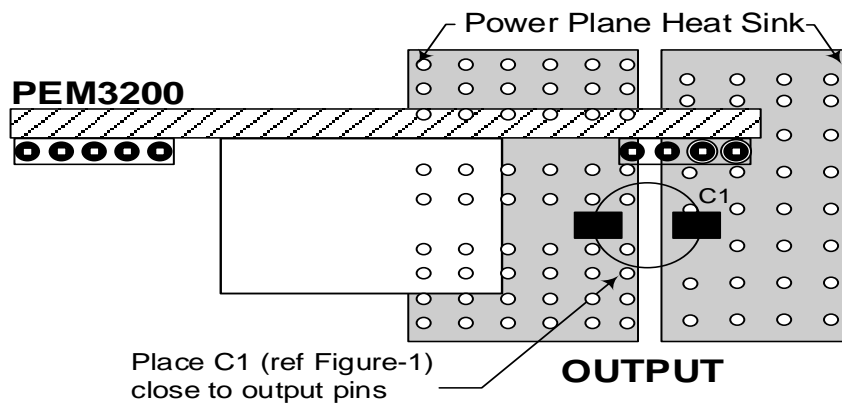

Figure 8- Power Plane Heat Sink

PHYSICAL PACKAGE

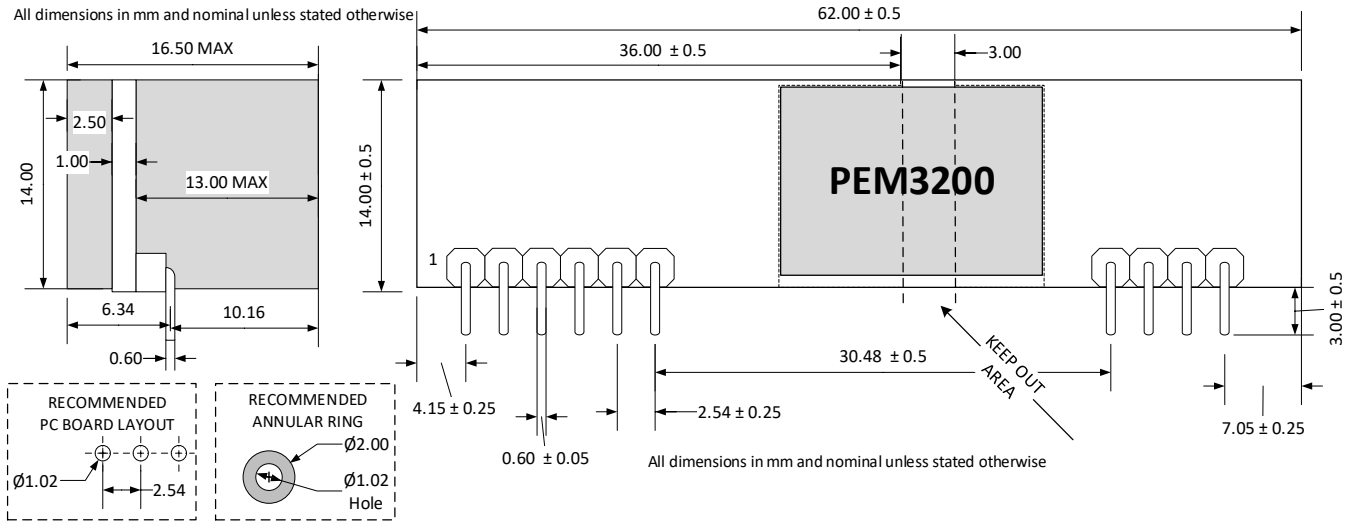

Figure 9- Mechanical Dimensions

APPLICATION NOTES

Power Over Ethernet (PoE) is a technology for wired Ethernet, the most widely installed local area network technology in use today. PoE allows the electrical power necessary for the operation of each end-device to be carried by data cables along with the data, rather than by separate power cords. Thus, it minimizes the number of wires used to install the network, resulting in lower cost, less downtime, easier maintenance and greater installation flexibility.

The IEEE standard governing PoE is IEEE802.3at and IEEE802.3af. Compliance with this standard ensures interoperability between devices.

The PEM3200 series modules offering a modular solution, incorporating Layer-1 IEEE802.3at/af compatibility signature to the PSE and isolated on-board DC/DC converter. The PEM3200 series are ideal modular system blocks allowing manufacturers of Ethernet equipment to “PoE enable” their equipment with minimal effort and cost. The PEM3200 modules series offer simple and quicker product development, maximising return on investment.

PEM3200 can be powered using a user designed power supply which has adequate thermal and over-current protection. It is strongly recommended that only IEEE802.3at/af compliant power supply equipment be used to prevent damage to the module, which lacks output stage thermal protection.

ESD AND SURGE PROTECTION

It is required that the system designer must provide ESD and surge protection such as a TVS diode, like SMAJ58A (Uni-Directional) or SMAJ58CA (bi-directional), at the PEM3200 input to prevent damage from over-voltage surges and for system EMC / ESD compliance.

ROHS REACH and CONFLICT MINERALS COMPLIANCE

ROHS, REACH, and Conflict Minerals compliance details are available on our website.

REVISION HISTORY

REVISION NUMBER	DESCRIPTION
21GR0-3	<ul style="list-style-type: none"> ▪ Image of the Product changed ▪ PRODUCT OVERVIEW updated ▪ Clerical corrections ▪ IEEE POE POWER CLASSIFICATION METHOD ▪ AT DETECTION (ATD Pin) updated
24CR1	<ul style="list-style-type: none"> ▪ Added typical Input Connections ▪ Datasheet Updated
24GR1	<ul style="list-style-type: none"> ▪ Output voltage adjustment resistors values are updated.
24JR1	<ul style="list-style-type: none"> ▪ Updated OUTPUT CONNECTION diagram
24LR1	<ul style="list-style-type: none"> ▪ Updated IEEE802.3 POWER LEVELS AND CLASSES
25AR6	<ul style="list-style-type: none"> ▪ Updated Dimension of keep out area
25CR7	<ul style="list-style-type: none"> ▪ Update in PHYSICAL PACKAGE

IEEE802.3 POWER LEVELS AND CLASSES
IEEE 802.3 Power levels and Classifications for POE Powered Devices

IEEE Standard	Common Name	PD Class	PD / PSE Type	Max num. of events	PD Power ¹	PSE Power ²	Wire pairs energised	AUC ³
802.3af	POE	0	1	-	12.95W	15.4W	2	No Support
802.3af	POE	1	1	1	3.84W	4W	2	No Support
802.3af	POE	2	1	1	6.49W	7W	2	No Support
802.3af	POE	3	1	1	12.95W	15.4W	2	No Support
802.3at	POE+	4	2	2	25.5W	30W	2	No Support
802.3bt	POE++	5	3	4	38.25W	45W	4	Optional
802.3bt	POE++	6	3	4	51W	60W	4	Optional
802.3bt	POE+++	7	4	5	62W	75W	4	Optional
802.3bt	POE+++	8	4	5	71.3W	90W	4	Optional

¹ Min. power delivered to PD / Module input. Max. PD / module output depends on operating conditions

² Power delivered from the Power Sourcing Equipment (PSE) (switch or injector) at its output port

³ Auto Class is supported. It is optional to enable or not.

www.poweredethernet.com. E.&O.E.

**Infomart India Pvt. Ltd.**

Infomart Tech Park

99, 5th Cross, 5th Block, Koramangala

Bangalore – 560 095, India

Tel: +91 80 4111-7200

Email: pesales@infomartgroup.com**Infomart Technologies**

Americas Sales Office

5904, South Cooper St. #104-96

Arlington, Texas, 76017, USA

Tel: +1 903-270-9090

Infomart India Pvt. Ltd. (Infomart®) products are sold subject to the general terms and conditions of commercial sale, as published at www.poweredethernet.com unless otherwise agreed on a written agreement. Infomart® reserves the right to make changes to any products herein, without further notice. The customer is responsible for its products and applications using Infomart® products, including compliance with all laws, regulations and safety requirements or standards, regardless of any support or applications information provided by Infomart®. “Typical” parameters which may be provided in Infomart® data sheets and / or in specifications can and do vary in different applications and actual performance may vary over time. Infomart® makes no warranty, representation or guarantee regarding the suitability of its products for any particular purpose, nor does Infomart® assume any liability arising out of the application or use of any product or circuit, and specifically disclaims any and all liability, including without limitation special, consequential or incidental damages. All operating parameters, including “Typical” must be validated for each customer application by customer’s technical experts. Infomart® products are not designed, intended, or authorized for use as a critical component in life support systems or any FDA Class 3 medical devices or medical devices with a same or similar classification in a foreign jurisdiction or any devices intended for implantation in the human body. Should Buyer purchase or use Infomart® products for any such unintended or unauthorized application, Buyer shall indemnify and hold Infomart® or and its officers, employees, subsidiaries, affiliates, and distributors harmless against all claims, costs, damages, and expenses, and reasonable attorney fees arising out of, directly or indirectly, any claim of personal injury or death associated with such unintended or unauthorised use, even if such claim alleges that Infomart® was negligent regarding the design or manufacture of the part. This document is subject to all applicable copyright laws and is not for resale and may not be altered in any manner. Infomart is a registered trademark of Infomart® (India) Pvt. Ltd. PoweredEthernet™ is a trademark of Infomart (India) Pvt. Ltd.

